

Getting Started with Crazy Patchwork

OK! First of all, let's settle the "rule" issue right here and now!!! There are no rules here, only creativity! It doesn't matter how you assemble your block or how the back of your block looks. Assembling the base block is just like embellishing, no rules! Just create, create, create!

The first thing you need is a constructed block on which to embellish. Decide what size the finished block will be and cut a base fabric 2" larger than the determined size. Draw the finished size (plus 1/2") square on the base fabric (see #1). For this demonstration, I used the "flip and sew" method.

This method can be done by hand; however, it is much faster and probably more sturdy by machine.

1. Begin by pre-cutting the center unit (see #1) and placing it on the base fabric right side up. Secure in place with a few drops of Roxanne's Glue Baste It or pin. Cut another piece of fabric and place right side down over the first fabric, lining up one edge. Size or shape doesn't matter with the second piece of fabric, just have one common edge. Sew on this edge, using a 1/4" seam allowance, through both fabrics and the base.

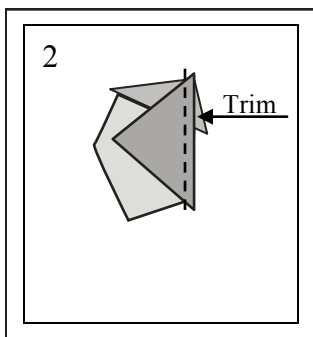
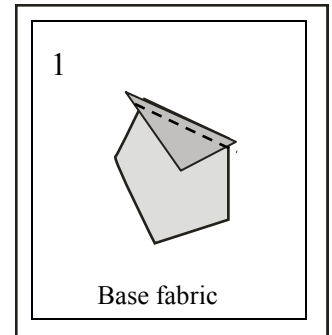

2. Flip the top piece over and press flat. Again, to secure, use a drop of glue or pin. Choose a third piece of fabric with an edge long enough to cover the first two pieces. Lay it right side down; sew, flip, TRIM (if necessary) and press.

HINT: If a seam has already been sewn down and you need to trim, simply unstash enough to trim away excess.

3. Continue stitching around the center block, going clockwise, until all edges of the center piece are stitches. Continue going around as many times as needed to cover the drawn square.

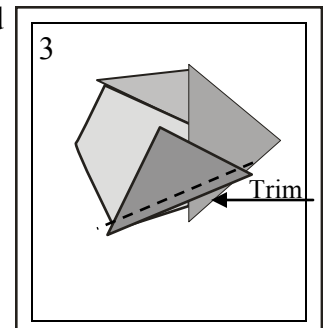

NOTE: It's OK to go a bit outside the marked patchwork area because you will mark the finished size plus 1/2" again.

When the desired size surface has been covered with fabric, do a final press. Lay the right side of the block face down into a terry cloth towel and press.

Take the block to a flat surface and do the following:

- Identify the stitching boundary lines by placing a square ruler over the block and drawing around it.
- It's OK if you choose not to use the same stitching boundary lines as is on the base fabric.
- Use a marking tool that will show up on the dark as well as the light fabrics.
- Stitch, using a sewing machine, on the stitching boundary line around the block.
- This will secure the bias edges and give a "stop stitching" line when you are adding the decorative stitches.

Now the fun begins!! Decorate each seam with beautiful stitches, lace, trims, beads, buttons, etc.

Alice Wilhoit
Author, Designer, Guild Programs & Teacher
www.alicewilhoit.com
(972) 540-5803